

KF T120

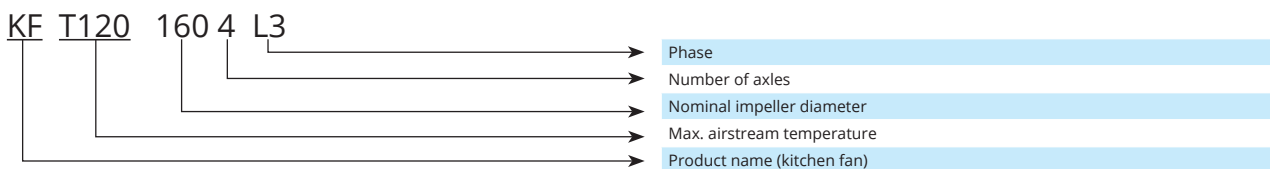

Features	<ul style="list-style-type: none"> › 9 sizes; › Airflow up to 3480 m³/h; › Forward- or backward-curved galvanized steel impeller; › Max air stream temperature - 120°C; › Easily serviceable; › Cost-effective.
Power supply	400V/50Hz/3f.
Temperature range	From -40°C up to 40°C.
Sizes	160-4L3, 180-4L3, 200-4L3, 225-4L3, 250-4L3, 280-4L3, 315-4L3, 355-4L3, 400-4L3.
Construction	<ul style="list-style-type: none"> › Casing: galvanized steel; › Acoustic and thermal wall insulation – 50mm; › Anti-vibration pads; › Easily removable grease tray; › Galvanized steel roofing; › On/Off safety switch (optional); › Fan: centrifugal impeller and external rotor motor; › Motor protection with built-in thermal contact; › Motor protection class: IP54.
Installation	<ul style="list-style-type: none"> › Can be installed outdoors. › Mounting position: vertical.
Speed control options	<ul style="list-style-type: none"> › Voltage controlled speed controller; › Frequency inverters.



Accessories

<p>Coupling</p> <p>NPU p. 194</p>	<p>Flexible connection for high temperature</p> <p>RC-MAN-PU p. 195</p>	<p>Air outlet</p> <p>AB p. 196</p>	<p>Frequency inverter</p> <p>FI p. 129</p>		
<p>0-10V speed controller</p> <p>MTP010 * p. 128</p>	<p>Controller</p> <p>Stouch* p. 130</p>	<p>Main switch</p> <p>Main switch p. 164</p>	<p>Controller</p> <p>SMT-D-4P-EL</p>	<p>SPS differential pressure transmitter</p> <p>S-1141** p. 161</p>	<p>Back draft shutter</p> <p>ATS p. 135</p>

KF T120

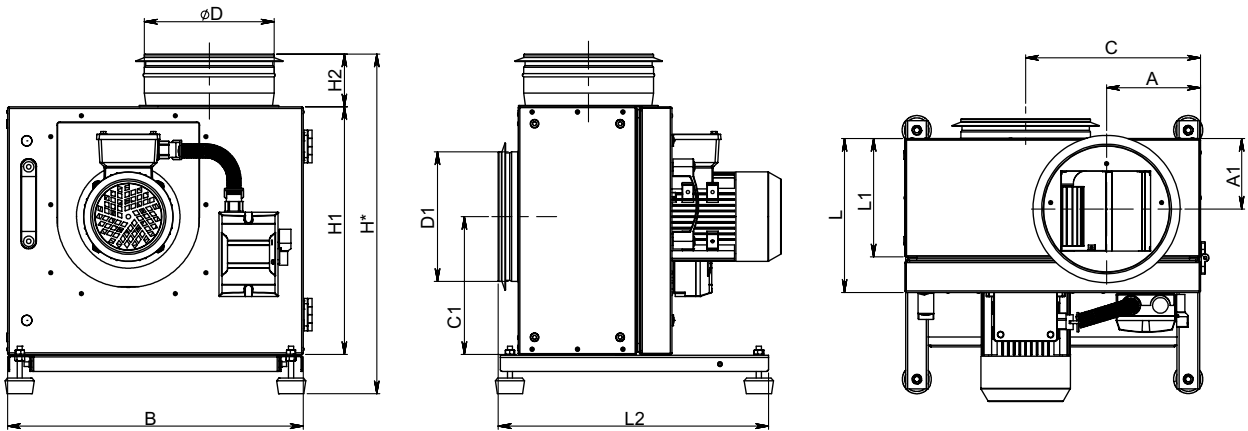

Type	Dimensions [mm]												
	ϕD	ϕD_1	L	L1	L2	H*	H1	H2	B	A	A1	C	C1
KF T120 160	200	200	228	173	414	496	355	80	413	123	109	237	195
KF T120 180	200	200	237	182	417	524	382	80	456	145	109	270	213
KF T120 200	200	200	250	196	500	548	407	80	484	145	117	287	228
KF T120 225	250	250	277	222	500	597	456	80	537	161	131	305	253
KF T120 250	315	315	290	136	620	651	500	90	577	170	146	342	278
KF T120 280	315	315	308	253	620	688	537	90	626	180	153	367	304
KF T120 315	315	315	298	242	620	752	600	90	695	195	142	410	339
KF T120 355	400	400	340	285	620	905	655	190	770	211	170	455	370
KF T120 400	400	400	358	298	620	890	640	190	750	202	170	450	355

Type	Accessories			
	Stouch* MTP010* S-1141**	TGRT	Mains	
			220-240V, 1-phase input, 3-phase output	380-480V, 3-phase input, 3-phase output
KF T120 160-4L3	+	1	ODE-3-12023-1F12	ODE-3-140022-3F12
KF T120 180-4L3	+	2	ODE-3-12023-1F12	ODE-3-140022-3F12
KF T120 200-4L3	+	3	ODE-3-120043-1F12	ODE-3-140022-3F12
KF T120 225-4L3*	+	-	ODE-3-120043-1F12	ODE-3-140022-3F12
KF T120 250-4L3*	+	-	ODE-3-120070-1F42	ODE-3-240058-3F42
KF T120 280-4L3	+	-	ODE-3-220105-1F42	ODE-3-240058-3F42
KF T120 315-4L3	+	1	ODE-3-120023-1F12	ODE-3-140022-3F12
KF T120 355-4L3	+	2	ODE-3-120023-1F12	ODE-3-140022-3F12
KF T120 400-4L3	+	3	ODE-3-120043-1F12	ODE-3-140022-3F12

* performance operating area is limited. Do not exceed the normal current, additional overload protection is required.
When frequency inverter is used for speed control, the shielded cable must be used for power supply.



* Can be used only with frequency inverters FI

** Pressure transducer S-1141 is supported only with the remote controller Stouch

KF T120

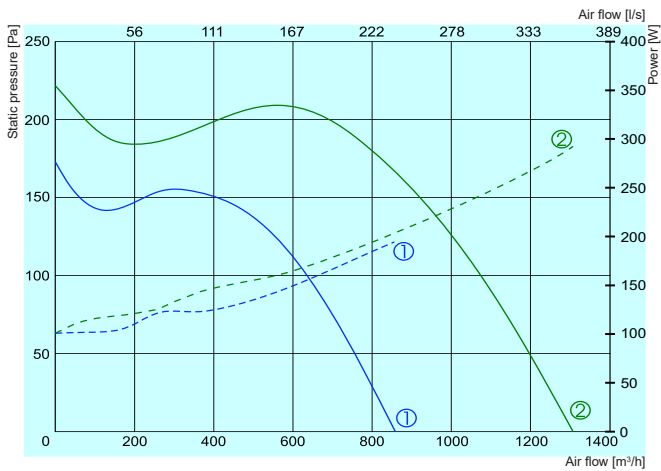

① ——— KF T120 160-4L3
 ② ——— KF T120 180-4L3

————— Performance
 - - - - - Power consumption

		160-4L3	180-4L3
Voltage/Frequency	[V/Hz]	~3,400/50	~3,400/50
Power consumption	[kW]	0,18	0,29
Current	[A]	0,57	1,0
Speed	[min ⁻¹]	1310	1340
Max. airflow	[m ³ /h]	849	1303
Min/Max ambient air temperature	[°C]	-40/+40	-40/+40
Weight	[kg]	22	25
Wiring diagram		No.1	No.1
Protection class:	motor	IP-54	IP-54
Comply with ERP 2018		*	*

*Fans for transportation of gases hotter than 100°C are not subject to ErP regulations.

160-4L3

	Lwa total, dB(A)	Lwa, dB(A)						
		125 Hz	250 Hz	500 Hz	1 kHz	2 kHz	4 kHz	8 kHz
Inlet	73	62	64	72	60	55	54	48
Outlet	75	63	69	73	59	60	56	50
Surrounding	56	47	52	53	43	40	38	33

Measured at 621 m³/h, 103 Pa

180-4L3

	Lwa total, dB(A)	Lwa, dB(A)						
		125 Hz	250 Hz	500 Hz	1 kHz	2 kHz	4 kHz	8 kHz
Inlet	76	65	67	75	63	58	57	51
Outlet	78	68	70	76	65	61	58	53
Surrounding	60	51	54	57	48	42	40	36

Measured at 1052 m³/h, 106 Pa

The fan characteristic curves were determined in accordance with EN ISO 5801. The sound levels were determined in accordance with DIN 45635 resp. ISO 3744 at a distance of 1 m from the fan.

KF T120

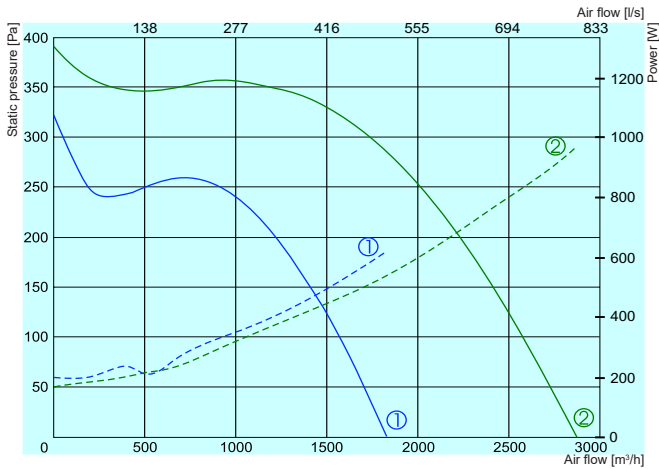

- ① — KF T120 200-4L3
- ② — KF T120 225-4L3
- Performance
- - - - Power consumption

		200-4L3	225-4L3
Voltage/Frequency	[V/Hz]	~3,400/50	~3,400/50
Power consumption	[kW]	0,54	0,92
Current	[A]	1,44	1,72
Speed	[min ⁻¹]	1390	1430
Max. airflow	[m ³ /h]	1826	2860
Min/Max ambient air temperature	[°C]	-40/+40	-40/+40
Weight	[kg]	29	34
Wiring diagram		No. 1	No. 1
Protection class:	motor	IP-54	IP-54
Comply with ERP 2018		*	*

*Fans for transportation of gases hotter than 100°C are not subject to ErP regulations.

200-4L3

LWA total, dB(A)	Lwa, dB(A)							
	125 Hz	250 Hz	500 Hz	1 kHz	2 kHz	4 kHz	8 kHz	
Inlet	79	69	72	77	65	63	58	55
Outlet	82	73	75	80	66	64	60	58
Surrounding	64	56	58	62	49	47	42	40

Measured at 1570 m³/h, 101 Pa

225-4L3

LWA total, dB(A)	Lwa, dB(A)							
	125 Hz	250 Hz	500 Hz	1 kHz	2 kHz	4 kHz	8 kHz	
Inlet	83	72	74	81	70	68	63	60
Outlet	85	75	79	82	71	69	65	61
Surrounding	69	59	63	66	54	51	47	44

Measured at 2585 m³/h, 102 Pa

The fan characteristic curves were determined in accordance with EN ISO 5801. The sound levels were determined in accordance with DIN 45635 resp. ISO 3744 at a distance of 1 m from the fan.

The company reserves the right to make changes of technical data without prior notice

KF T120

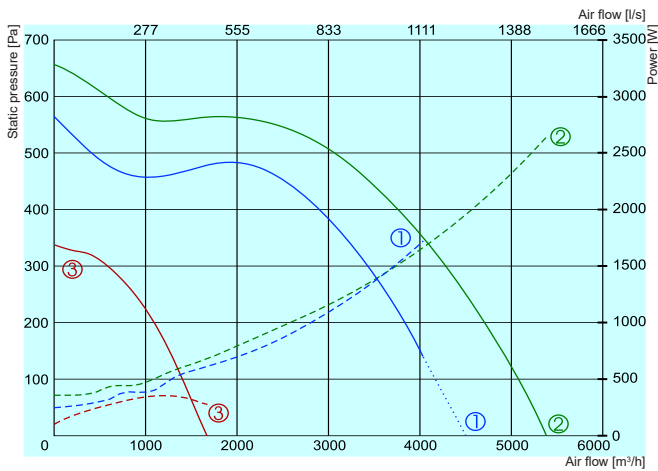

- ① KF T120 250-4L3
 - ② KF T120 280-4L3
 - ③ KF T120 315-4L3
- Performance
 - - - Power consumption
 Not operating zone

		250-4L3	280-4L3	315-4L3
Voltage/Frequency	[V/Hz]	~3,400/50	~3,400/50	~3,400/50
Power consumption	[kW]	1,6	2,66	0,18
Current	[A]	3,37	4,7	0,68
Speed	[min ⁻¹]	1430	1440	1330
Max. airflow	[m³/h]	3860	5236	1676
Min/Max ambient air temperature	[°C]	-40/+40	-40/+40	-40/+40
Weight	[kg]	55	45	45
Wiring diagram		No.1	No.1	No.1
Protection class:	motor	IP-54	IP-54	IP-54
Comply with ERP 2018		*	*	*

*Fans for transportation of gases hotter than 100°C are not subject to ErP regulations.

250-4L3

Lwa total, dB(A)	Lwa, dB(A)							
	125 Hz	250 Hz	500 Hz	1 kHz	2 kHz	4 kHz	8 kHz	
Inlet	86	78	80	83	73	70	67	63
Outlet	88	80	81	86	75	74	66	65
Surrounding	72	64	66	68	59	56	49	48

Measured at 3860 m³/h, 190 Pa

280-4L3

Lwa total, dB(A)	Lwa, dB(A)							
	125 Hz	250 Hz	500 Hz	1 kHz	2 kHz	4 kHz	8 kHz	
Inlet	90	82	83	88	75	71	68	67
Outlet	92	85	83	89	78	76	68	69
Surrounding	74	67	68	71	60	56	51	50

Measured at 5077 m³/h, 100 Pa

315-4L3

Lwa total, dB(A)	Lwa, dB(A)							
	125 Hz	250 Hz	500 Hz	1 kHz	2 kHz	4 kHz	8 kHz	
Inlet	78	67	73	74	66	64	56	54
Outlet	80	69	74	77	67	65	59	55
Surrounding	63	53	59	59	50	47	40	38

Measured at 1401 m³/h, 100 Pa

The fan characteristic curves were determined in accordance with EN ISO 5801. The sound levels were determined in accordance with DIN 45635 resp. ISO 3744 at a distance of 1 m from the fan.

KF T120

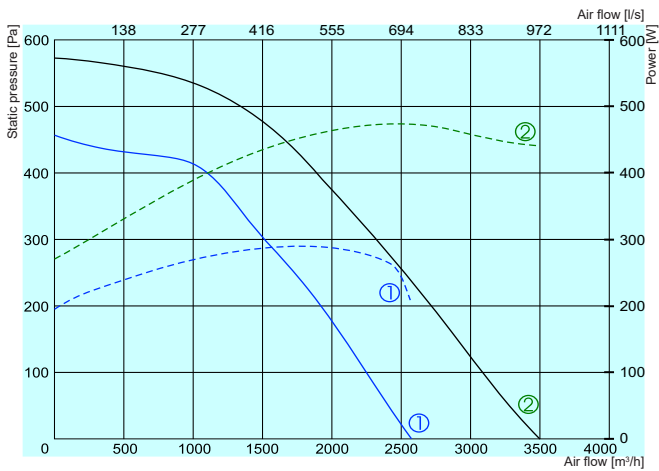

① — KF T120 355-4L3
 ② — KF T120 400-4L3

— Performance
 - - - Power consumption

		355-4L3	400-4L3
Voltage/Frequency	[V/Hz]	~3,400/50	~3,400/50
Power consumption	[kW]	0,29	0,47
Current	[A]	0,98	1,45
Speed	[min ⁻¹]	1340	1390
Max. airflow	[m³/h]	2561	3487
Min/Max ambient air temperature	[°C]	-40/+40	-40/+40
Weight	[kg]	53	56
Wiring diagram		No.1	No.1
Protection class:	motor	IP-54	IP-54
Comply with ERP 2018		*	*

*Fans for transportation of gases hotter than 100°C are not subject to ErP regulations.

KITCHEN FANS

355-4L3

	LWA total, dB(A)	Lwa, dB(A)						
		125 Hz	250 Hz	500 Hz	1 kHz	2 kHz	4 kHz	8 kHz
Inlet	84	75	78	82	71	70	63	58
Outlet	86	77	79	83	73	72	65	61
Surrounding	67	61	62	63	56	54	47	43

Measured at 2219 m³/h, 104 Pa

400-4L3

	LWA total, dB(A)	Lwa, dB(A)						
		125 Hz	250 Hz	500 Hz	1 kHz	2 kHz	4 kHz	8 kHz
Inlet	86	77	76	82	80	74	69	68
Outlet	88	79	81	85	78	75	71	70
Surrounding	71	63	65	67	63	58	53	52

Measured at 2956 m³/h, 134 Pa

The fan characteristic curves were determined in accordance with EN ISO 5801. The sound levels were determined in accordance with DIN 45635 resp. ISO 3744 at a distance of 1 m from the fan.

The company reserves the right to make changes of technical data without prior notice

KF T120

Wiring diagram No. 1*

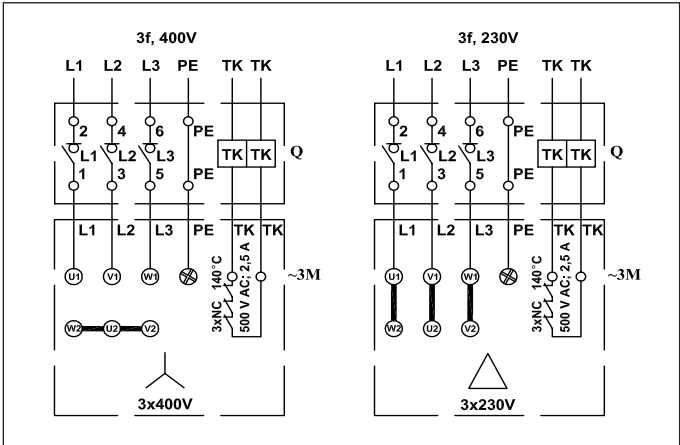

Q - switch
M - fan motor

* Fans must be connected with frequency inverters (if used) with screened cable complying EMC standards.

KITCHEN FANS

